

ITEM	PART #	DESCRIPTION	QTY.
1	1050.32	1.66 RAILING BASE FLANGE	1
2	1058.32	1.66 BASE FLANGE	1
3	1060.32	1.66 WALL FLANGE	1
4	1061.32	1.66 RAIL BRACKET	1
5	1081.32	BASE SWIVEL KIT	1

REVISIONS				
ZONE	REV.	DESCRIPTION	DATE	APPROVED

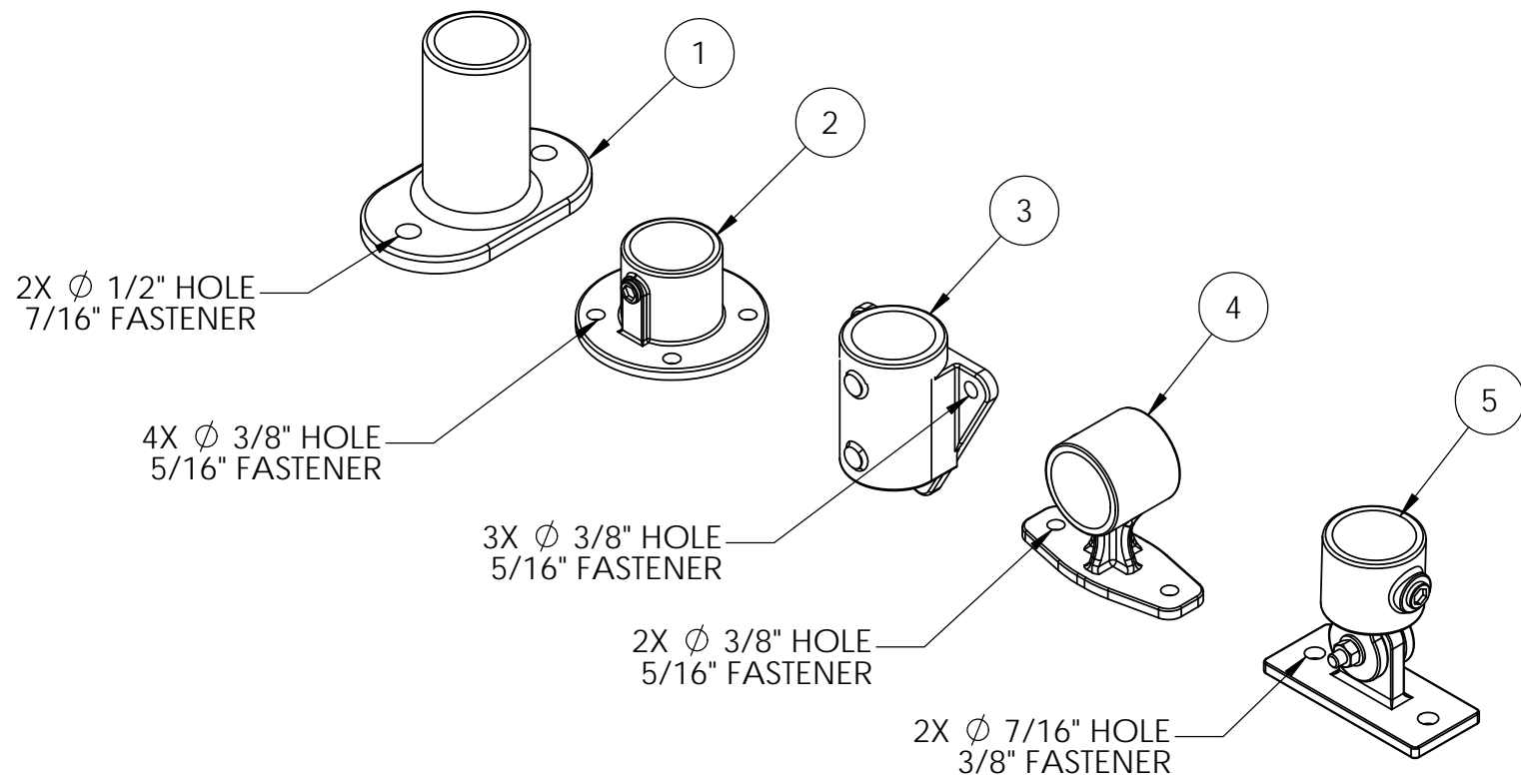

UNLESS OTHERWISE SPECIFIED: DIMENSIONS ARE IN INCHES TOLERANCES: FRACTIONAL ±1/8 ANGULAR: MACH ±.5° BEND ±1° ONE PLACE DECIMAL ±.1 TWO PLACE DECIMAL ±.03 THREE PLACE DECIMAL ±.010	NAME	DATE
	DRAWN	JDB 10/15/13
	CHECKED	
	ENG APPR.	
	MFG APPR.	



4064 PEAVEY ROAD
 CHASKA, MN 55318
 866-933-2935
 www.bluewater-mfg.com

TITLE:
**-32 FITTING MOUNTING
 HOLE DIMENSIONS**

PROPRIETARY AND CONFIDENTIAL
 THE INFORMATION CONTAINED IN THIS DRAWING IS THE SOLE PROPERTY OF BLUEWATER MFG., INC. ANY REPRODUCTION IN PART OR AS A WHOLE WITHOUT THE WRITTEN PERMISSION OF BLUEWATER MFG., INC IS PROHIBITED.

INTERPRET GEOMETRIC TOLERANCE PER: ASME Y14.5.M-1994	COMMENTS:
MATERIAL CAST STEEL	
FINISH ----	
DO NOT SCALE DRAWING	

SIZE A	DWG. NO. ----	REV A
SCALE: 1:4	WEIGHT:	SHEET 1 OF 1